

BYKERO BIKE
HANDBOOK

System 2005



All rights reserved. No part of this publication may be reproduced, stored in a retrieval system or transmitted in any form, electronic, mechanical, photocopying, recording or other means without prior written permission from JOLLY ROGER (Amusement Rides) Ltd.

JOLLY ROGER (Amusement Rides) Ltd reserves the right to make changes, for the purpose of product improvement, at any time.

Jolly Roger (Amusement Rides) Ltd. Heath Road, Skegness Industrial Estate, Skegness, Lincolnshire, PE25 3SU, England.

Telephone: + 44 (0) 1754 896800
Fax: + 44 (0) 1754 610066
E-mail: sales@jolly-roger.co.uk

This handbook was prepared for Jolly Roger (Amusement Rides) Ltd
by
Lionbridge (UK) Ltd.,
Enterprise Centre,
Coventry University Technology Park,
Puma Way
Coventry
CV1 2TT

JOLLY ROGER AMUSEMENT RIDES

CONTENTS

	INTRODUCTION	
	WARNINGS AND CAUTIONS	
1.1	Health and safety - code of safe practice at fairs - Industry Standards (UNITED KINGDOM)	
	INSTALLATION	
2.1	Siting	
	OPERATION	
3.1	General	
	MAINTENANCE	
4.1	General	
4.2	Control unit	
4.3	Coin acceptor (mechanical)	
4.4	Coin acceptor (electronic) MARS	
4.5	Electronic coin mechanism MARS - switch positions	
4.7	Stamar "Plug n Play Kiddie ride controller credit programming instructions	
4.8	Stamar "Plug n Play Kiddie ride controller credit programming instructions	
4.9	SW1 sets the price of play value or credit programme options	
4.10	Ride Time	
4.11	Additional ride features	
4.12	Ride flasher options	
4.13	Volume adjustment	
4.14	Access to other components	
4.15	Drive belt adjustment	
4.18	Bearings	
4.19	Fuses	
4.20	Body and other mouldings	
4.21	Removal of body shell	
4.22	Removal of bottom access covers	
4.23	Daily checks	
4.24	Cash box	
4.25	Motor	
	SPARE PARTS	
	Conditions of Business	
	Annex A Manufacturer's test certificate	
	Annex B EC Declaration of Conformity	

Fig.		Page
1	Programmable control unit - (System 2005)	10/11
2	Chassis assembly	18
3	Timer and card reader wiring diagram	20
4	Dash PCB wiring diagram	21
5	Coin collection assembly and interior components	22
6	Body shell assembly	24

JOLLY ROGER AMUSEMENT RIDES

INTRODUCTION

Thank you for purchasing your new Kiddie Ride from Jolly Roger (Amusement Rides) Limited and we trust it will give many years of trouble-free profitable service.

Whilst this booklet has been produced primarily with our United Kingdom and European customers in mind, it will certainly be of benefit to other users worldwide.

Reference is made to the United Kingdom Health and Safety at Work Act - Code of Safe Practice at Fairs (which specifically includes coin operated Children's Rides), the Industry Standard for the construction, operation and use of coin-operated Children's Rides, and the EC Declaration of Conformity (CE Mark).

The Rides comply with United Kingdom and European Community regulations, and are ETL listed to comply with US Standard UL 22 covering Amusement Games covering motor operated appliances.

The rides are designed for intermittent use and the maximum anticipated duty cycle is 30 operations per hour.

The guidance given in this publication is relevant to the safe operation of children's rides wherever they may be operated.

WARNINGS & CAUTIONS

The international safety sign is used throughout this Handbook where specific safety precautions are detailed. The sign is positioned so that the precautions are readily identifiable.

INTERNATIONAL SAFETY SIGN

WARNING



WARNINGS

Warnings call attention to instructions, which must be followed precisely to avoid injury or death.

CAUTIONS

Cautions call attention to instructions, which must be followed precisely to avoid damaging the equipment.

JOLLY ROGER AMUSEMENT RIDES

HEALTH AND SAFETY - CODE OF SAFE PRACTICE AT FAIRS - INDUSTRY STANDARDS

(UNITED KINGDOM)

1.1 Our equipment has been manufactured to the highest standard of construction and safety in order to conform to the H.S.E. Fairground and Amusement Parks, A Code of Safe Practice and the U.K. Health and Safety at Work Act 1974.

1.2 This machine must be earthed. (CONNECTED TO GROUND)

1.3 If a 13 Amp BS1363 plug is fitted then a 5 amp fuse should be fitted. (UK only)

1.4 If the ride is to be situated outdoors, the socket outlet supplying the power should be connected by a permanent weatherproof plug protected by a residual current circuit breaker (RCCB) or an Earth Leakage Circuit Breaker (ELCB) having a trip rating not exceeding 30 milliamps in 30 milliseconds.

1.5 In addition to our manufacturer's test and the daily checks every ride shall be subject to a Thorough Examination by an appointed person once every period of 14 months. (UK Health and Safety at Work Act - Code of Safe Practice at Fairs). The regulation applies in the UK only, however it is sound operating practice wherever a ride is operated.

1.6 The appointed person need not be independent, but should be at least 21 years old, registered under the Amusement Device Inspection Procedures Scheme (ADIPS) and be competent by such qualifications, knowledge, experience and supporting services to be able to make an assessment of the safety of the ride, including any associated equipment/parts e.g. electrical, hydraulic or pneumatic.

1.7 The appointed person should have the technical competence to recognise the significance of the effects of stresses, loadings and fatigue and also be competent to determine the extent of permissible wear.

1.8 The Thorough Examination is to be carried out by a registered body in accordance with the regulations laid down in the Health and Safety at Work Act 1974 (Fairgrounds and Amusements Parks-Guidance on Safe Practice, HSG 175). A Report of Inspection is to be completed after the Thorough Examination. (Applicable in UK only).

1.9 On completion of the Thorough Examination, a Declaration of Operational Compliance (DOC) certificate is to be issued which must be retained for a period of ten years and be available for inspection by the Health and Safety Inspectorate and/or the appropriate officer of the Environmental Health Department of a Local authority. (Applicable in UK only).

WARNING ALWAYS DISCONNECT THE MACHINE FROM THE POWER SUPPLY BEFORE CARRYING OUT ANY SERVICE OR REPAIR.



1.10 If considered necessary, further protection to the power supply may be afforded by conduit, trunking, or rubber protector strip with tapered edges and non-slip ribbed bases. Care is needed to avoid a tripping hazard.

1.11 The Kiddie Rides should be so sited that the length of cable between the ride and socket outlet is a minimum. For floor mounted socket outlets, the ride may be positioned so that there is virtually no exposed cable.

1.12 Galvanised steel braided armoured cable and flexible copper braided cable cannot be satisfactorily terminated in a 13 amp standard (BS 1363) plug. Such cables can be terminated in industrial type plugs BS 196 or BS 4343 or equivalent, but these require the special suitable sockets. (Applicable in UK only).

JOLLY ROGER AMUSEMENT RIDES

HEALTH AND SAFETY - CODE OF SAFE PRACTICE AT FAIRS - INDUSTRY STANDARDS

(CANADA ONLY)

Standard CSA E60335-1, Clause 7.12.1 requires that for appliances not rated at least IPX5, the instructions shall state that “the appliance is not suitable for installation in an area where a water jet could be used”.

Standard CSA E60335-1, Clause 7.12.5 requires that the mains supply cord is damaged; it must be replaced by an equivalently rated type.

Standard CSA E60335-1, Clause 7.12.1 requires that for appliances not rated at least IPX5, the instructions shall state that “the appliance is not suitable for installation in an area where a water jet could be used”.

Standard CSA E60335-1, Clause 7.12.1 requires that the installation instructions for moving ride appliances shall state the free space necessary around the appliance for safe operation.

Standard CSA E60335-1, Clause 7.12.1 requires that the installation instructions for Kiddie rides shall state that the installation of a residual current device(RCD)having a rated residual operating current not exceeding 30mA is advisable.

JOLLY ROGER AMUSEMENT RIDES

INSTALLATION

Siting

WARNING



IT IS NOT RECOMMENDED THAT THE RIDE BE SITED ON A PLINTH, PLATFORM OR ANY FORM OF MATTING. DOING THIS WILL INCREASE THE HEIGHT OF THE RIDE FROM THE GROUND AND MAY CAUSE INJURY FROM FALLING OR TRIPPING.

2.1 A common sense approach should be adopted when siting Kiddie Rides. The following items are an indication, but not exhaustive:

- 2.1.1 Position the Ride on a level surface.
- 2.1.2 Ensure there is adequate clearance all round the Ride to minimise the risk of injury to the passengers or public. If possible, a 1 metre clearance around the ride is recommended.
- 2.1.3 **DO NOT** obstruct emergency exits.
- 2.1.4 **DO NOT** obstruct fire appliances, hydrants etc.
- 2.1.5 **DO NOT** locate the ride directly against the plug, which should remain accessible at all times
- 2.1.6 The ride is not suitable for installation or operation in an area where a water jet could be used

CAUTION



For safety reasons the electrical wiring is colour coded as follows:

2.1.7 For rides with 220-240 volt electrical supply, the wiring colour codes are:

Brown - live
Green/Yellow-earth
Blue – neutral.

2.1.8 For rides with 110-120 volt electrical supply, the wiring colour codes are:

Black - live
Green - earth
White – neutral.

WARNING



ALWAYS DISCONNECT THE MACHINE FROM THE POWER SUPPLY BEFORE CARRYING OUT ANY SERVICE OR REPAIR.

INSTALLATION

Site d'installation

AVERTISSEMENT



IL N'EST PAS RECOMMANDE DE CONDUIRE SUR UNE PENTE, RAMPE OU AUTRE AFIN DE NE PAS ELEVER LA HAUTEUR DU VEHICULE ET NE PAS CAUSER DE BLESSURES EN RAISON DE RENVERSEMENT OU D'ACCROCHAGE.

2.1 Faites appel à votre bon sens quand vous choisissez le site d'installation des manèges pour enfants. Les points suivants sont donnés à titre indicatif mais ne sont pas exhaustifs:

2.1.1 Placer le manège sur une surface nivelée.

2.1.2 S'assurer qu'il y a suffisamment d'espace tout autour du manège pour minimiser le risque de blessures pouvant être causées aux passagers ou au public. Si c'est possible, il est conseillé de laisser 1 mètre d'espace tout autour du manège.

2.1.3 **NE PAS** obstruer les sorties de secours.

2.1.4 **NE PAS** obstruer les bouches d'incendie et la voie de passage des voitures de pompiers.

2.1.5 **NE PAS** installer le manège directement contre la prise; cette dernière devrait toujours être accessible.

2.1.6 Il n'est pas convenable d'installer ou de faire marcher le manège dans un endroit où l'on pourrait utiliser des jets d'eau.

AVERTISSEMENT



Pour des raisons de sécurité, le circuit électrique est repéré par couleurs comme indiqué ci-dessous:

2.1.7. Pour les manèges alimentés en 220-240 volt, le circuit électrique est le suivant:

Marron : phase
Vert/Jaune : terre
Bleu : neutre.

2.1.8 Pour les manèges alimentés en 110-120 volt, le circuit électrique est le suivant:

Noir : phase
Vert : terre
Blanc : neutre.

AVERTISSEMENT



TOUJOURS DEBRANCHER LA MACHINE DE L'ALIMENTATION SECTEUR AVANT D'EFFECTUER TOUTE REPARATION OU TOUTE VERIFICATION.

JOLLY ROGER AMUSEMENT RIDES

OPERATION

General

3.1 A coin-operated Kiddie Ride should not be used unless a D.O.C. has been provided, indicating that the device is safe to operate (UK Health and Safety at Work Act - Code of Safe Practice at Fairs). This regulation applies in the UK only.

JOLLY ROGER AMUSEMENT RIDES

MAINTENANCE

General

4.1 The rides do not require any periodic maintenance but, they should be checked regularly to ensure that they are in a safe condition for operation by the general public. In the unlikely event of the need to make adjustments or repairs to the machine, the following procedures are recommended.

Standard CSA E60335-1, Clause 7.12 annex ZE requires that the instructions shall indicate the type and frequency of inspections and maintenance required for safe operations including the preventive maintenance measures.

WARNING



ALWAYS DISCONNECT THE MACHINE FROM THE POWER SUPPLY BEFORE REMOVING ANY COVERS OR COIN MECHANISMS.

Control unit

4.2 The control unit, which operates at 12 volts, is located at the back of the coin acceptor compartment. To remove/refit the control unit proceed as follows:

4.2.1 Remove the coin acceptor (para 4.3 or 4.4).

4.2.2 Remove the two thumb nuts located at each end of the unit.

4.2.3 The control unit may now be removed by pulling it forwards and withdrawing it through the coin acceptor aperture in the cash box assembly.

4.2.4 The mode of operation may now be altered by referring to the basic configuration, as printed on its enclosure, or by referring to the advanced configuration referred to at para 4.7.

4.2.5 Refit the unit by positioning it on the two locator bolts and gently pushing it back into place, ensuring that the plugs and sockets connect to each other.

4.2.6 Refit the two thumb nuts to ensure a good connection between the plugs and sockets. A poor connection could result in failure of the unit.

Coin acceptor (mechanical)

4.3 To remove/refit the coin acceptor proceed as follows:

4.3.1 Remove the coin acceptor by turning the lock situated on the faceplate - the coin acceptor can now be removed from the machine and the wires pulled off the coin acceptor microswitch if desired.

NOTE

Ensure that the wires are reconnected on the correct terminals (C and NO).

4.3.2 To remove litter from the coin acceptor, slide off the spring clip on the top of the mechanism and remove side plate, then remove any litter or obstruction.

4.3.3 Refit the coin acceptor in reverse order to removal, ensuring that the pins on the main coin acceptor body locate in the dimples on the side plate.

4.3.4 Adjusting screws for coin diameter and thickness are also located on the side plate, these are factory set and should not normally require alteration.

JOLLY ROGER AMUSEMENT RIDES

Coin acceptor (electronic) MARS

4.4 To remove/refit the coin acceptor proceed as follows:

4.4.1 Remove the coin acceptor by turning the lock situated on the faceplate and disconnect the cable plug from the printed circuit board on the mechanism - the coin acceptor can now be removed from the machine.

4.4.2 To remove litter from the coin acceptor, pull the hinged side plate sideways and remove any litter or obstruction. Release hinged side plate.

4.4.3 Refit the coin acceptor in reverse order to removal, ensuring that the cable plug is reconnected to the printed circuit board on the mechanism.

WARNING NEVER REMOVE OR REPLACE AN ELECTRONIC MECHANISM WITH THE POWER SUPPLY SWITCHED ON.



Electronic coin mechanism MARS - switch positions

4.5 To inhibit coins:

With machine switched on:

4.5.1 Set slide switches as follows, 1 = ON, 2 = ON, 3 = OFF, 4 = ON.

4.5.2 Press reject button within 20 seconds of setting slide switches.

4.5.3 Insert all coins to be inhibited.

4.5.4 Press reject button within 20 seconds of inserting coins. Inhibited coins should now be rejected.

4.6 To re-enable inhibited coins:

With machine switched on:

4.6.1 Set slide switches as follows, 1 = ON, 2 = ON, 3 = OFF, 4 = OFF.

4.6.2 Press reject button within 20 seconds of setting slide switches.

4.6.3 Insert all coins to be re-enabled.

4.6.4 Press reject button within 20 seconds of inserting coins. Previously inhibited coins should now be accepted.

NOTE

Mechanism must be powered up before changing switch positions. Switch positions must be moved prior to attempting either of the above.

JOLLY ROGER AMUSEMENT RIDES

Stamar “Plug n Play” Kiddie Ride Controller Credit Programming Instructions

4.7 The “Plug n Play” Timer Unit can now be programmed “on-site” for any Credit functions as shown by the following instructions. This facility is incorporated on all software from JR450 onwards

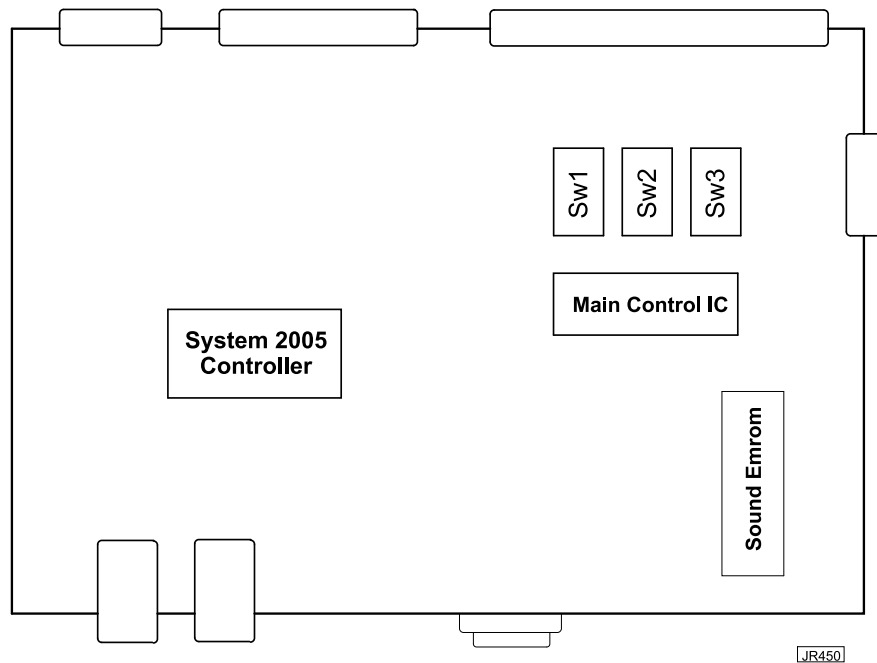

Fig 1 System 2005 Programmable Control Unit

Credit Programming sequence

1. Turn Ride OFF
2. Make a note of the current SW1 settings
3. Set ALL SW1 switches to the OFF position
4. Turn the Ride ON
5. Enter coins to the value of the first Credit value
6. Press the Ride Start Switch for the number of rides required for this credit value
7. Insert coins for the next credit value required
8. Press the Ride Start Switch for the next number of rides required
9. Repeat this process until ALL credit values have been entered
10. Now PRESS and HOLD the Ride Start Switch until the voice prompt announces that the programming is completed, approximately 4-5 seconds
11. Turn the Ride OFF
12. Set ALL SW1 switches to the ON position
13. The new Credit Program is now installed
14. If at any time during the process, you wish to cancel the programming function, simply turn the Ride OFF and re-set the original SW1 positions. This will restore the previous credit program

JOLLY ROGER AMUSEMENT RIDES

Stamar “System 2005” Kiddie Ride Controller Configuration Instructions

4.8 The new “System 2005” programmable control unit has four externally accessible DIL switches, SW1, SW2, and SW3, which are used to select the most popular modes of operation.

NOTES

1. It is advisable to remove the control unit from the ride as this will assist viewing the switches and referring to these instructions. The control unit can be easily “unplugged” from the ride **AFTER POWER TO THE RIDE HAS BEEN SWITCHED OFF** and the two mounting bolts have been removed.
2. All alterations to these switches should only be made after power to the ride has been turned off as this will avoid any unintentional damage to the control unit and/or the ride.

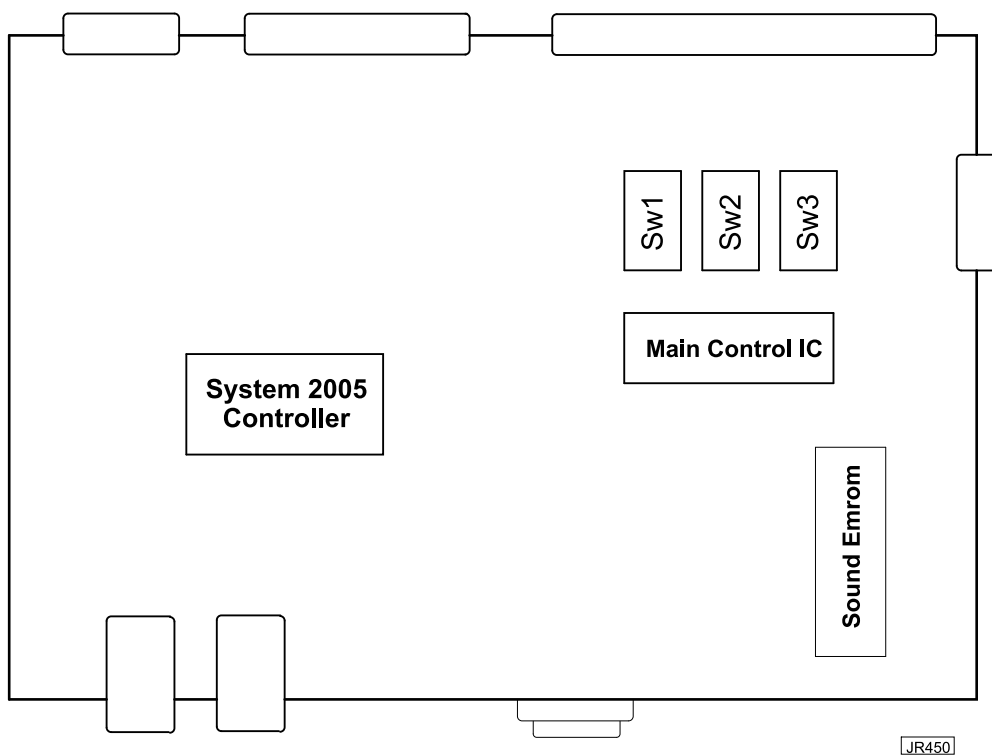

Fig 1 System 2005 Programmable Control Unit

JOLLY ROGER AMUSEMENT RIDES

SW1 sets the Price of Play value or Credit Program Options.

4.9 The SW1 switch is used to set price at play value or credit program options.

NOTES

1. The setting for **either** “price of play” **or** “credits” on SW1 as shown below are selected using **SW3/S4** as shown in SW3 settings below.

i.e. SW3/S4 must be set to On if “Price of Play” options are required.

SW3/S4 must be set to Off if “Credit Programs” are required.

2. The **Price of Play** refers to multiples of the **Base Coinage** that the coin mechanism has been programmed to accept:

- UK Mechanism. The mechanism is programmed for a 10p base and gives play values from 10p (1 coin) to £1.50 (15 coin).
- USA Mechanism. The mechanism is programmed for a 25c base and gives play values from 25c (1 coin) to \$3.75 (15 coin).

SW1

S1	S2	S3	S4	Price Of Play Selected	Or	Pre - Programmed Credit Options Available
on	off	off	off	1 Coin	Or	30 P 1 RIDE 50 P 2 RIDES £1 5 RIDES
off	on	off	off	2 Coin	Or	20 P 1 RIDE 50 P 3 RIDES
on	on	off	off	3 Coin	Or	40 P 1 RIDE £1 3 RIDES
off	off	on	off	4 Coin	Or	50 P 1 RIDE £1 £2 3 RIDES 6 RIDES
on	off	on	off	5 Coin	Or	60 P 1 RIDE £1 £2 2 RIDES 5 RIDES
off	on	on	off	6 Coin	Or	10 P 1 RIDE 30 P 4 RIDES
on	on	on	off	7 Coin	Or	£1 1 RIDE £2 3 RIDES
off	off	off	on	8 Coin	Or	£2 1 RIDE
on	off	off	on	9 Coin	Or	20 P 1 RIDE 40 P 3 RIDES
off	on	off	on	10 Coin	Or	10 P 1 RIDE 20 P 3 RIDES
on	on	off	on	11 Coin	Or	60p 1 RIDE £1 £2 2 RIDES 4 RIDES
off	off	on	on	12 Coin	Or	70p 1 RIDE £1 £2 2 RIDES 4 RIDES
on	off	on	on	13 Coin	Or	
off	on	on	on	14 Coin	Or	Free Play For Exhibition Or Test Use
on	on	on	on	15 Coin	Or	Programmable By User
off	off	off	off	User on site Programming Mode		

JOLLY ROGER AMUSEMENT RIDES

SW2 is used to set Ride time

4.10 SW2 is used to set the ride time. The ride time can be set from 30 seconds to 120 seconds in 15 second increments or to run for as long as the main background soundtrack. Other ride times are available on request

SW2

Ride Time	S1	S2	S3	S4
30 secs	off	off	off	OFF
45 secs	on	off	off	OFF
60 secs	off	on	off	OFF
75 secs	on	on	off	OFF
90 secs	off	off	on	OFF
105 secs	on	off	on	OFF
120 secs	off	on	on	OFF
Ride time set to soundtrack	on	on	on	OFF

NOTE

S4 is used for a diagnostic test sequence during manufacture and under normal operating conditions is not used and **must be set to the OFF position.**

Additional ride features

4.11 SW3 selects additional ride features.

SW3

	S1	S2	S3	S4
Prompt phrases On/Off	On/Off	x	x	x
Attract sounds On/Off	x	On/Off	x	x
Count no. of Rides	x	x	On	x
Count No. of Coins (coin mech. Base coin value)	x	x	Off	x
Select <i>Price of Play</i> options	x	x	x	On
Select <i>Credit Program</i> options	x	x	x	Off

JOLLY ROGER AMUSEMENT RIDES

Ride flasher options

4.12 SW4 selects the ride flasher options (if fitted).

SW4

S1	S2	S3	S4
----	----	----	----

1 Channel flasher output	Off	Off	x	OFF
2 Channel running flasher outputs	On	Off	x	OFF
3 Channel running flasher outputs	Off	On	x	OFF
4 Channel running flasher outputs	On	On	x	OFF
Standard flasher speed	x	x	Off	OFF
Fast flasher speed	x	x	On	OFF

NOTE

S4 is used to select “Program Mode” and under normal operating conditions is not to be used and must be set to the **OFF** position. “Program Mode” should only be used by experienced operators familiar with the extended programming sequence, or under direct instruction from Jolly Roger (Amusement Rides) Ltd., or Stamar Electronics.

Volume adjustment

4.13 Access to the volume control knob is gained by removing the coin mechanism (para 4.3 or 4.4) and is adjusted by turning the control knob on the timer which is located on the back wall of the compartment.

Access to other components

4.14 Access to the Power supply unit (PSU), main fuses and other components on the chassis is gained by removing the bottom cover (para 4.22).

Drive belt adjustment

4.15 The “final drive” belt is adjusted by loosening the four bolts holding the camshaft bearings and sliding the whole assembly to adjust.

NOTE

This belt should run tight.

4.16 The “countershaft” belt is adjusted by loosening the four bolts holding the motor and sliding the motor to adjust.

NOTE

This belt should run quite loose.

4.17 Both belts are correctly tensioned during manufacture and should not require adjustment.

Bearings

4.18 All bearings are greased for life and should normally not be re-packed with grease. However, in certain circumstances the bearings may require lubrication. If this situation arises, apply grease sparingly.

JOLLY ROGER AMUSEMENT RIDES

Fuses

4.19 Fuses are located in the side of the PSU. Never replace fuses with a higher value than recommended.

Body and other mouldings

4.20 Clean with damp cloth rinsed out in soapy water, do not hose down or flood the machine. Alternatively, a proprietary household furniture cleaner may be used.

Removal of body shell

WARNING



ALWAYS DISCONNECT THE MACHINE FROM THE POWER SUPPLY BEFORE CARRYING OUT ANY SERVICE OR REPAIR.

CAUTION



Care is to be taken when carrying out steps 4.21.1 and 4.22.1

NOTE

Refer to Figure 5 in Spare Parts section for item numbers.

4.21 To remove the body shell proceed as follows

4.21.1 Turn ride on to its side.

4.21.2 Remove the four nuts and washers situated under the body shell, which attach the body to the chassis.

4.21.3 Disconnect the electrical wiring underneath the body shell by undoing the plug and socket connector.

4.21.4 Remove body shell.

Removal of bottom access covers

4.22 To remove the access covers proceed as follows

4.22.1 Turn ride on to its side.

4.22.2 Remove the four security retaining screws that secure the bottom covers.

4.22.3 Refit in reverse order to the removal.

Daily checks

4.23 A check of each coin-operated Kiddie Ride should, whenever reasonably practical, be carried out each day before it is made available for the public. The following checks are recommended: -

4.23.1 Check that the mains plug is undamaged and securely attached to the mains cable.

4.23.2 Check that the mains cable is undamaged.

4.23.3 Check that there are no broken or damaged parts of the ride that may cause injury.

4.23.4 Apply pressure to the ride to ensure that it is firmly secured to the base stem and check that all advisory literature is in place.

JOLLY ROGER AMUSEMENT RIDES

4.23.6 Ensure the area around the ride is free from obstruction and that persons passing by are not in any danger.

4.23.7 The ride should be kept clean and free from any customised additions unless approved by the manufacturer.

If as a result of the above visual checks any doubt arises, then the company, supplier or person responsible for the ride should be notified immediately.

CEC version - no cash box fitted

Steel base version - with cash box

4.24 To empty the cash box unlock the cash drawer at rear of the ride base and remove the contents making sure the cash box is made secure again.

Motor

The motor is fitted with a manual re-set thermal overload cut-out device in accordance with UL requirements.

4.25 When the motor does not operate, check if the thermal overload cut-out device has operated and re-set as follows:

CAUTION



When the thermal overload cut-out device has operated, investigate and correct the fault before the ride is returned to use.

4.25.1 Disconnect the machine from the electrical power supply.

4.25.2 Remove the bottom covers from the machine (para 4.22).

4.25.3 Re-set the thermal overload cut-out button on the motor backplate.

4.25.4 Refit the bottom covers to the machine (para 4.22).

4.25.5 Connect the electrical power and test the ride.

JOLLY ROGER AMUSEMENT RIDES

SPARE PARTS

NOTE

For Video Ride Equipment - Spare Parts, refer to the Video Ride Equipment Handbook.

1. The machine serial number (if given) on the reference plate must always be quoted.
2. Quote the full part number and description as set out in the list.
3. State precisely how parts are to be despatched.

Home: By post, carrier or road transport.

Overseas: By sea freight, airmail or air freight.
4. Keep orders separate from other correspondence.
5. Foreign orders must be sent through our accredited agent, an established London House, or accompanied by a remittance.
6. Replacement parts which are not of genuine Jolly Roger supply, cannot be relied upon to be to the correct specification, material or workmanship. Jolly Roger therefore cannot be expected to extend their Warranty to Kiddies Rides which have been fitted with parts which Jolly Roger has not supplied.
7. Jolly Roger reserve the right to make changes or improvements in the construction or specification of their products at any time.

Conditions of Business

1. Particulars given in this list are subject to withdrawal and alteration without notice.
2. All quotations are subject to confirmation before acceptance of order.
3. All goods are supplied on the conditions that Jolly Roger shall not be liable for any direct or consequential damage arising from delay in delivery or from defective material, other than is covered by our usual form of guarantee.
4. Whilst every effort is made to ensure the accuracy of the particulars contained in this book, modifications and specification changes to the Kiddies Ride are on-going. These may affect the information specified. No responsibility is accepted for the incorrect supply of parts or any other consequence that may arise as a result of information in this book not being in accord with modifications or Kiddies Ride specification changes which are subsequent to the date of this book. Also, no responsibility is accepted for the incorrect supply of parts or any other consequence that may arise as a result of any misinterpretation of the information specified in this parts book.

JOLLY ROGER AMUSEMENT RIDES

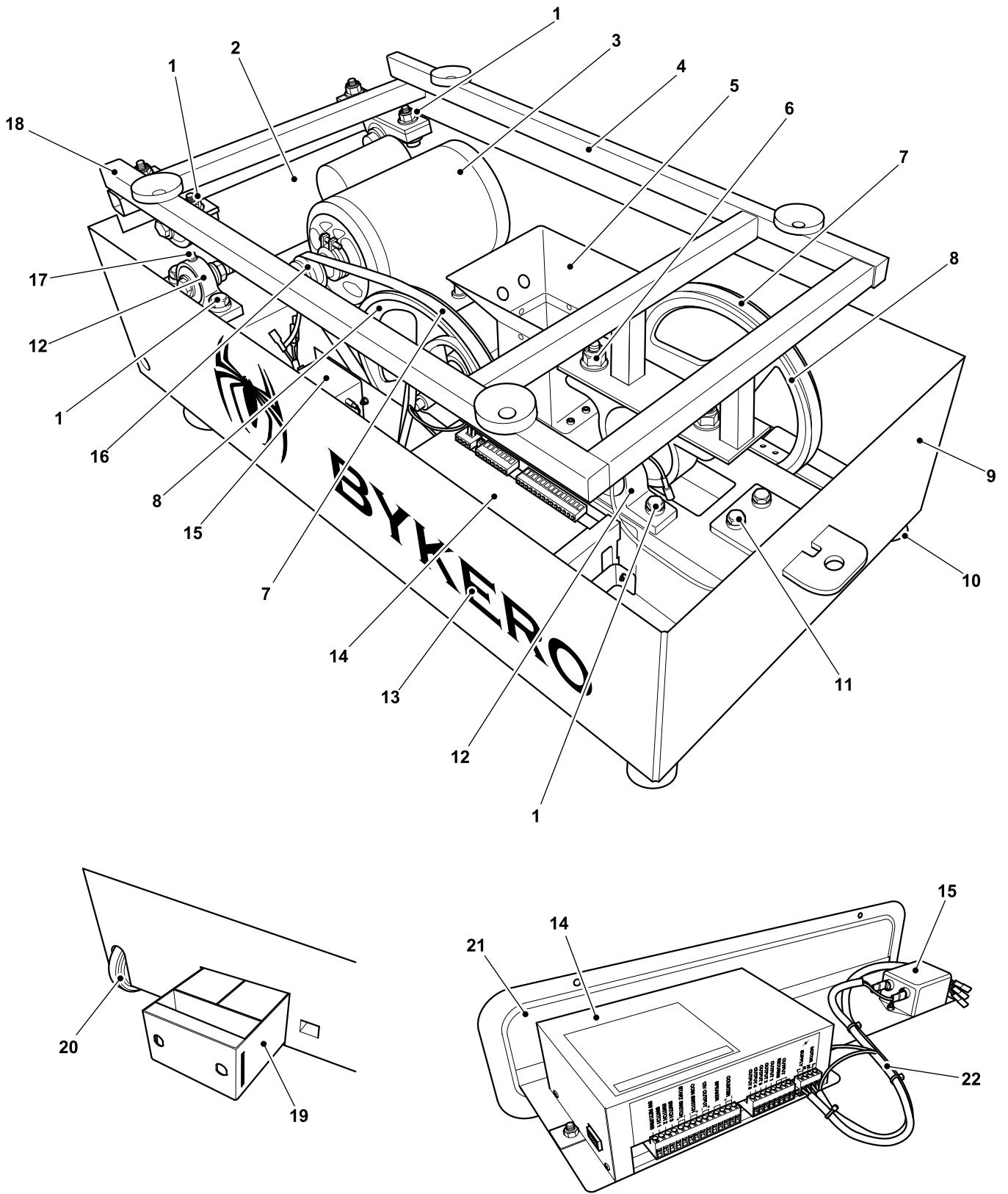

Fig 2 Chassis assembly

JOLLY ROGER AMUSEMENT RIDES

Parts list - Bykero Bike Chassis assembly

† Item not illustrated

Item No	Part No	Description	QTY
-		Chassis assembly, comprising:	-
1	7700200	Nut, , Nyloc, M10	16
-	7000604	Bolt, M10 x 35	16
-	7600200	Washer, M10	16
2	N/S	Arm, pivot	1
3	GR146A	Motor, 220/240 volts 50 Hz	1
-	† BB717	Housing, bearing assembly, SL40	1
4	N/S	Support frame, body shell	1
5	N/S	Coin collection shute	1
6	7000707	Bolt, M12 x 50	2
-	7600300	Washer, M12	4
-	7700300	Nut, M12, Nyloc	2
7	GR117	Belt, vee A 33(A 870)	2
8	8000000	Pulley, 224 SPA x 12mm x 1A	2
-	† 8200000	Camshaft	1
-	† 7700300	Nut, M12, Nyloc, camshaft	2
-	† 7600300	Washer, M12, camshaft	2
9	N/S	Base fabrication	1
10	GR114	Foot, adustable	2
11	7000503	Bolt, M8 X 25	4
-	7600100	Washer, M8	4
-	7700100	Nut, , Nyloc, M8	4
12	BB015	Housing, bearing assembly, NP12	6
13	????	Decal, BYKERO	1
14	JR100C	Power supply unit	1
15	EE417	Filter	1
16	8000001	Pulley, 43 SPA x 1/2 in x 1A	1
17	9100000	Nipple, grease	5
18	7700300	Nut, M12, Nyloc	4
-	7600300	Washer, M12	8
-	7000707	Bolt, M12 x 50	4
19	N/S	Cash box	1
20	CC007A	Wheel	2
21	N/S	Shelf fabrication, PSU and filter	1
22	N/S	Wiring loom	1

Note: Refer to manufacturer when ordering items from this list

JOLLY ROGER AMUSEMENT RIDES

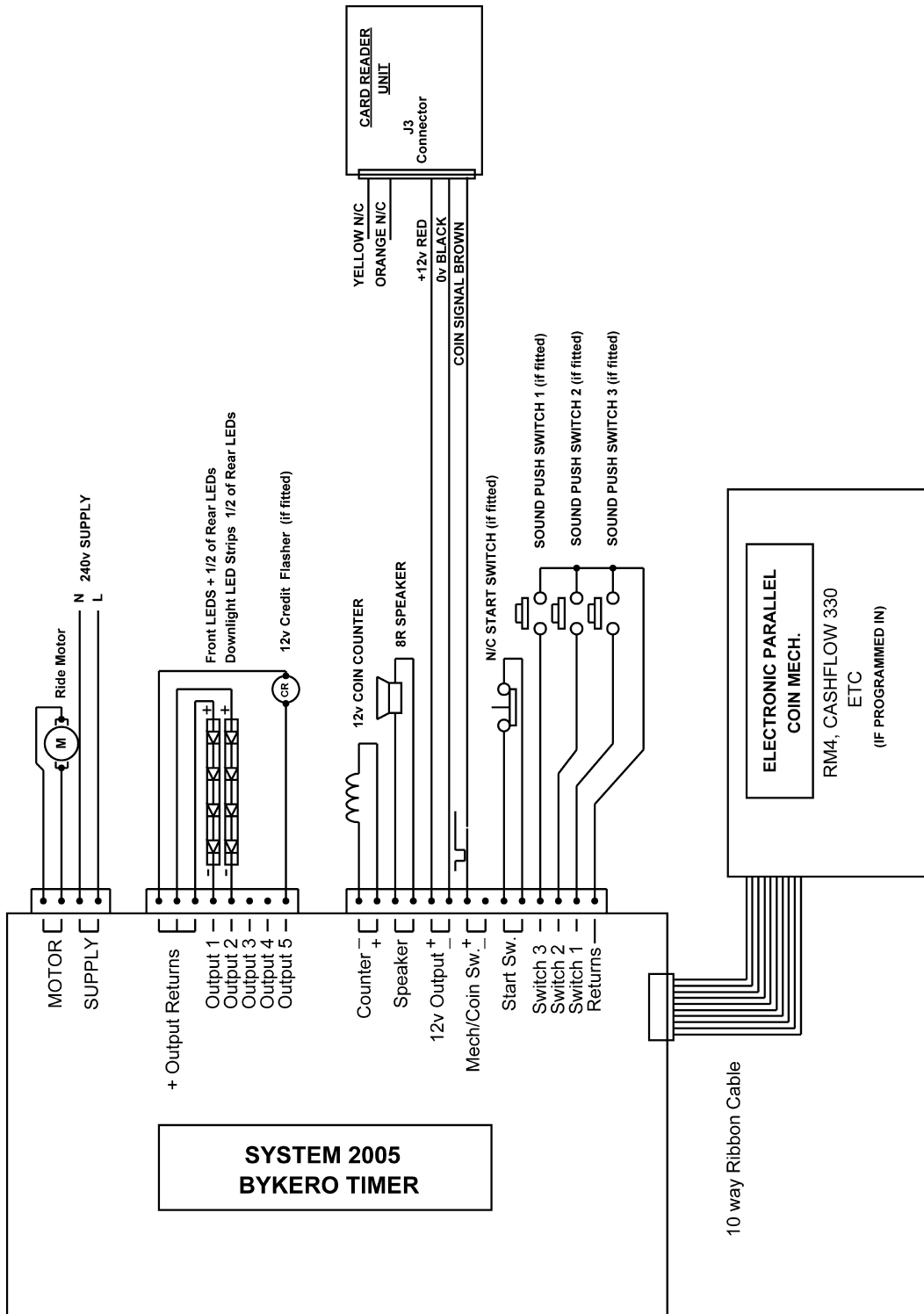

Fig 3 Timer and Card Reader Wiring Diagram

JOLLY ROGER AMUSEMENT RIDES

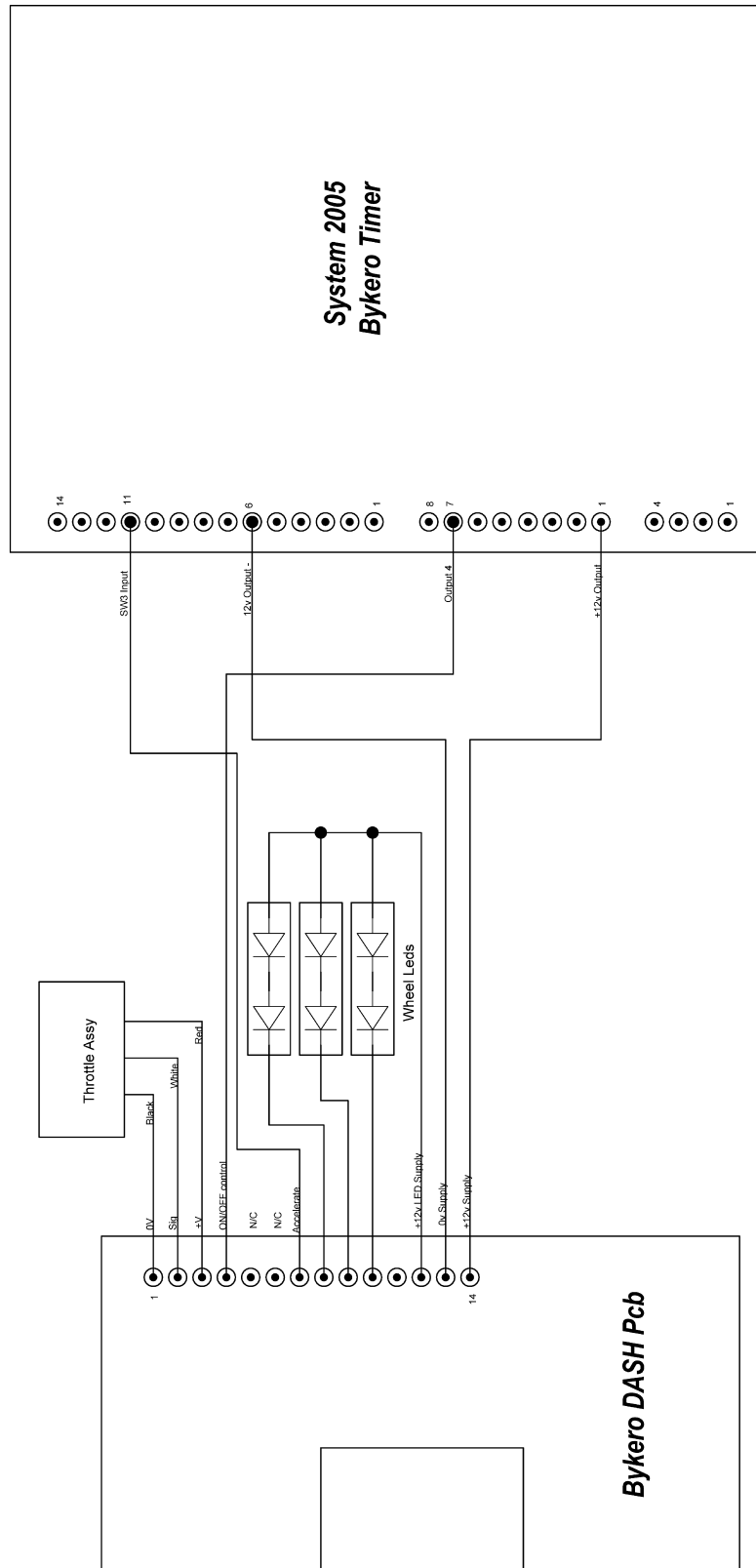

Fig 4 Dash PCB Wiring Diagram

JOLLY ROGER AMUSEMENT RIDES

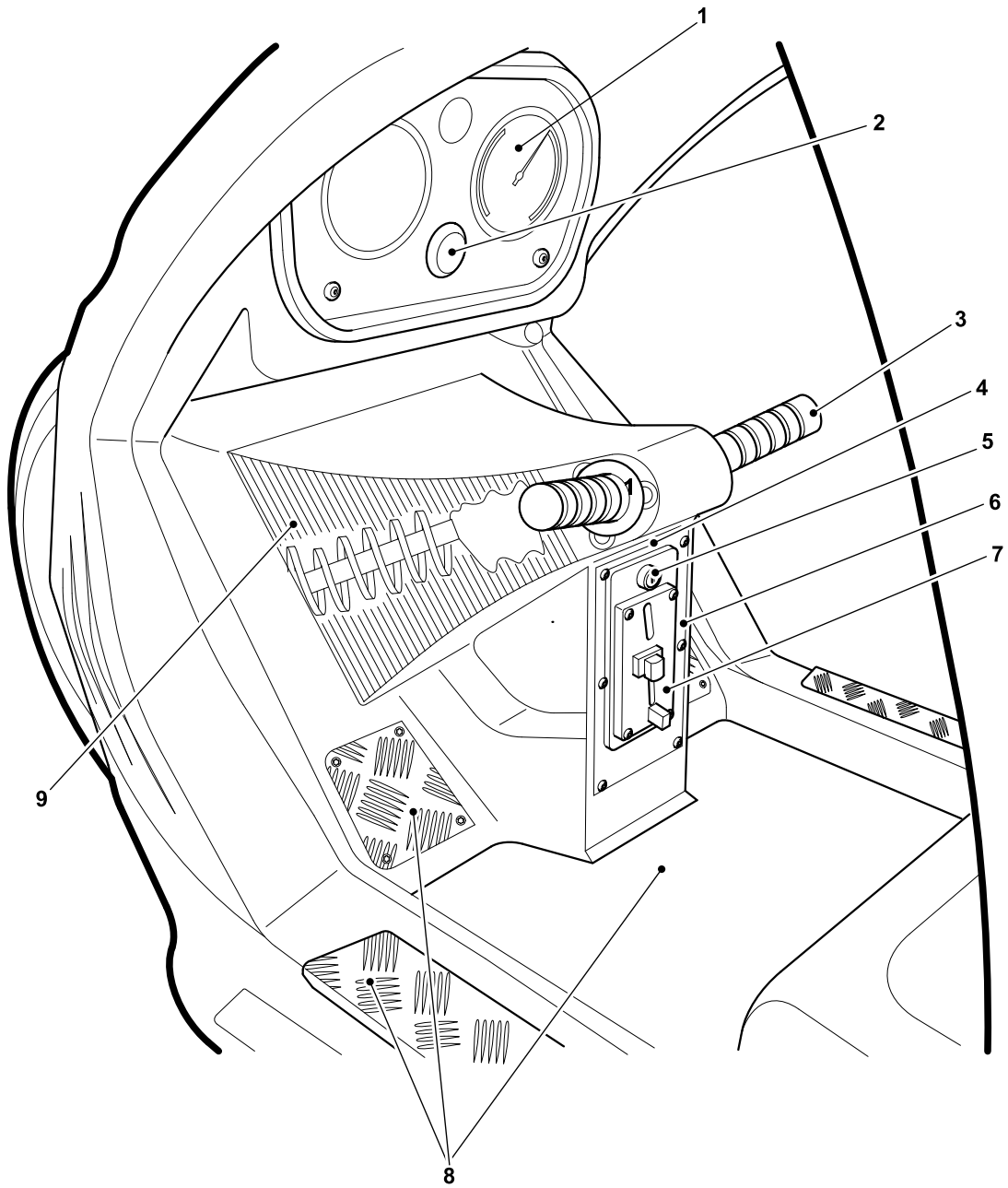

Fig 5 Coin collection assembly and interior components

JOLLY ROGER AMUSEMENT RIDES

Parts list - Bykero Bike Coin collection assembly and interior components

† Item not illustrated

Item No	Part No	Description	QTY
-		Coin collection assembly and interior comonents comprising:	-
1	JR201	Dash board, electronic	1
2	GR182	'START' Button, green, round	1
3	EE694	Throttle grip, handle bar	2
4	JR94A	Surround, coin mechanism	1
5	GR188	JR4 Lock (sales rides)	1
-	† GR220	JR4 Key (sales rides)	1
6	JR94	Mounting plate, coin acceptor	1
-	† JR94B	SWIPE READER PLATE - USA ONLY	1
7	GR144C	Mini front plate, coin acceptor (sales rides)	1
8	BR293	Foot plate set, anti slip	1
9	TT855A	Decal, shock absorber LH	1
-	† TT855B	Decal, shock absorber RH	1
-	† TT855	Decal set,complete PMI	1

Note: Refer to manufacturer when ordering items from this list.

JOLLY ROGER AMUSEMENT RIDES

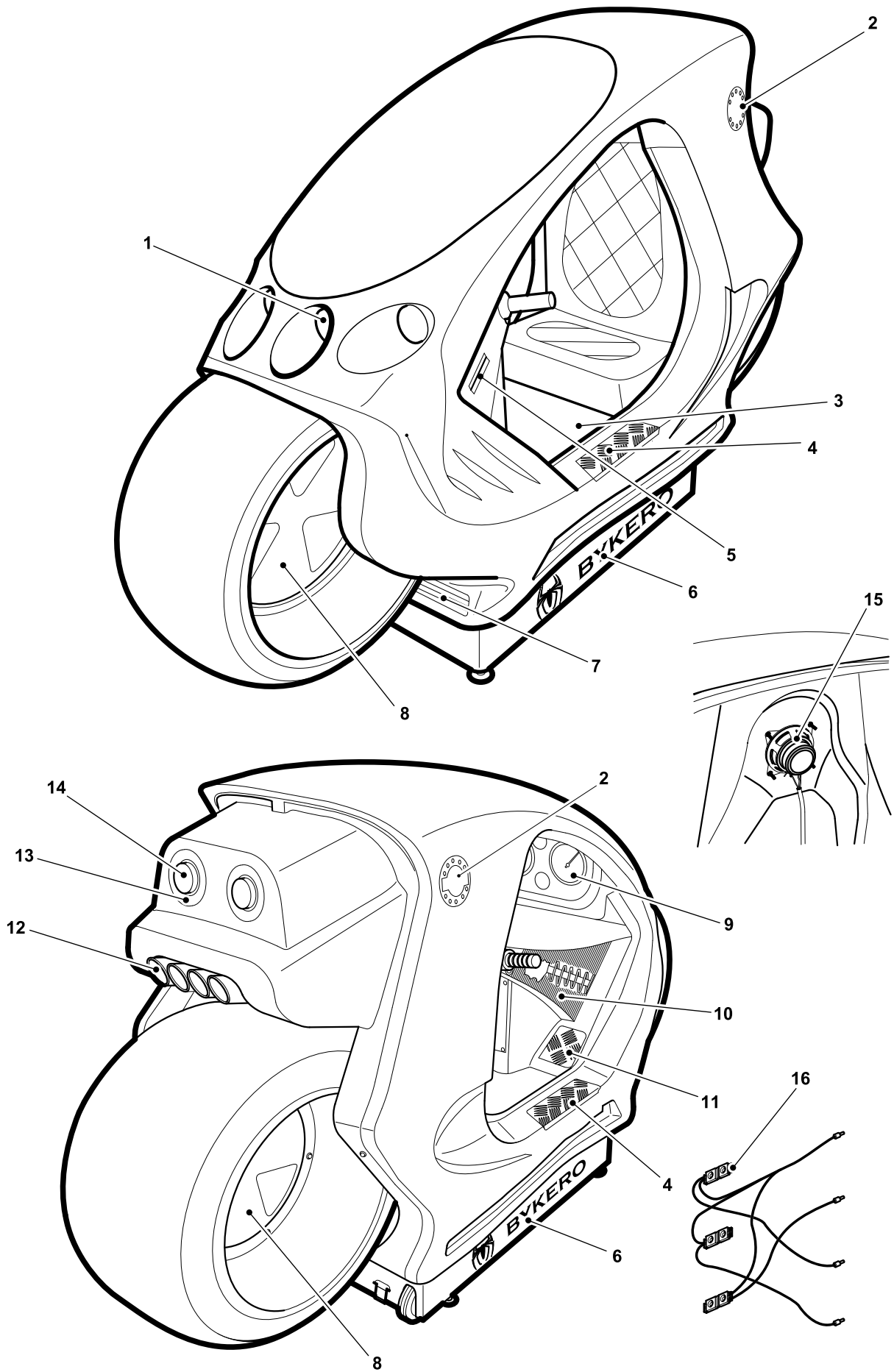

Fig 6 Body shell assembly

JOLLY ROGER AMUSEMENT RIDES

Parts list - Body Shell Assembly

† Item not illustrated

Item No	Part No	Description	QTY
Body shell assembly - Bykero Bike comprising:			
1	EE028	Headlamp, (2 per set)	4
2	TT855/C	Filler cap, decal	1
3	BR293	Floor, anti slip, (part of set)	1
4	BR293	Foot plate, anti slip, (part of set)	2
5	TT855/A	Shock obsorber, decal LH	1
6	TT855/D	'BYKERO' decal	2
7	TT855/E	Grill, decal	1
8	CA188	Wheel	2
9	JR205	Dash board	1
10	TT855/B	Shock obsorber, decal RH	1
11	BR293	Foot plate, upper, anti slip, (part of set)	2
12	GR099	Exhaust tail pipe	2
13	EE028A	Rear light, outer - clear/orange	2
14	EE028B	Rear light, inner - orange/red	2
-	† BR042	Bracket, rear light (4 per set)	1
-	† TT855	Decals, full set	1
15	EL002	Speaker	1
16	N/S	Lights loom, wheels	2

Note: Refer to manufacturer when ordering items from this list

JOLLY ROGER AMUSEMENT RIDES

We certify that we have manufactured and tested the coin-operated Children's Ride in accordance with the BACTA Industry Standard, the HSE Fairgrounds and Amusement Parks A Code of Safe practice, the Health and Safety at Work Act 1974. (All applicable in the United Kingdom).

We certify that we have manufactured and tested the coin-operated Children's Ride in accordance with United States Standard ANSI/UL22 and Canadian C.S.A. Standard C22.2 No. 68.92 and in particular have carried out tests for Earth bonding and dielectric strength. The rides have also been tested and comply with requirements of FCC Part 15, Class A.

THIS CERTIFICATE DOES NOT EXONERATE THE OPERATOR FROM REGULAR CHECKING AND MAINTENANCE OF THE MACHINE TO WHICH IT APPLIES.

Jolly Roger (Amusement Rides) Ltd.
Heath Road,
Skegness Industrial Estate,
Skegness,
Lincolnshire,
PE25 3SU,
England.

Telephone (01754) 896800 Telefax (01754) 610066

E-mail: sales@jolly-roger.co.uk

JOLLY ROGER AMUSEMENT RIDES

THIS PAGE NOT USED